

PL200 KIT
FEUILLE D'INSTALLATION
PL200 KIT
INSTALLATION SHEET

1. Installation

BRANCHEMENT POUR PL200 SECTEUR ÉLECTRIQUE

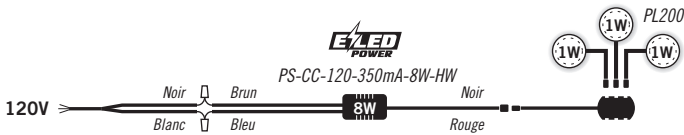

BRANCHEMENT POUR PL200 PRISE MURALE



6068 Métropolitain Est
Montréal (Québec), H1S 1A9
514.448.1574
1 886 653-3533
Télec. / Fax : 514.903.0649
info@lumnergie.com
www.lumnergie.com

Le leader Canadien en éclairage DEL

DECOBEL ^{BY/PAR} Lumnergie
Canadian leader in LED lighting

Safe, Fast and Easy to install with the EZLED POWER
Installation simple et rapide avec le système de connexion
EZLED POWER



1. Installation

PL200 HARD WIRE CONNECTION

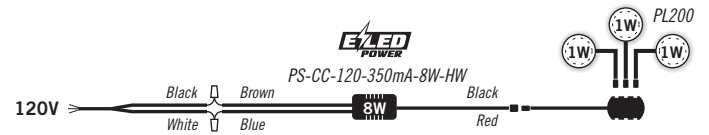

PL200 PLUG IN CONNECTION

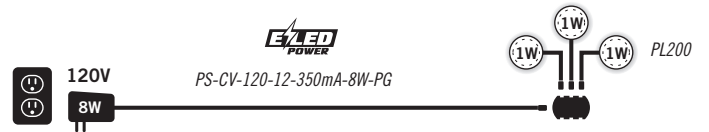

2. Tableau des grandeurs

Item	Diamètre ext.	Diamètre perc.	Hauteur
PL200	2"1/2	2"1/8	1"1/16

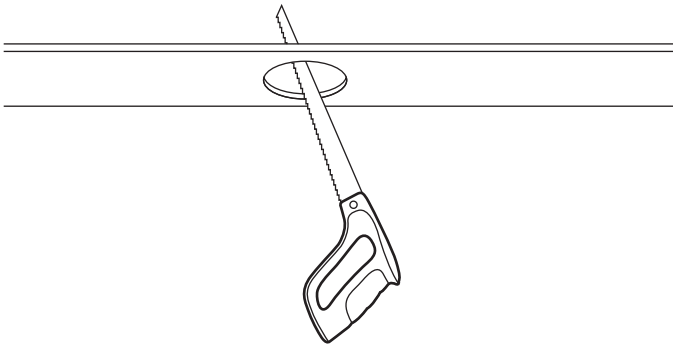

2. Size Chart

Item	Ext. Diameter	Hole Diameter	Height
PL200	2"1/2	2"1/8	1"1/16

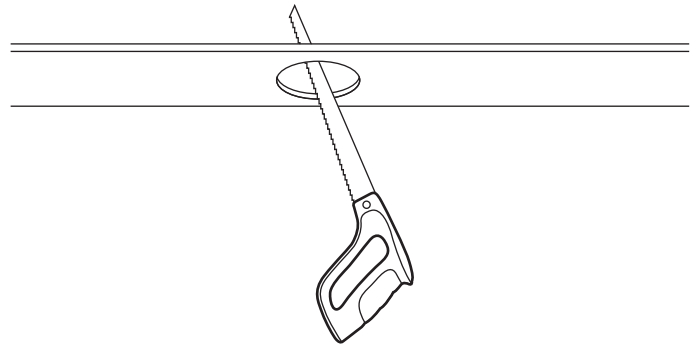

4. Certifications

BLOC D'ALIMENTATION



Composantes reconnues par les laboratoires UL.



Certification des Underwriters Laboratories concernant la sécurité du produit.



Mise en garde

1. Toujours brancher la charge de lumière avant de mettre le courant!
2. Veuillez suivre le code du bâtiment et ne pas installer sans protection conforme à moins de 3 pouces de toute isolation.
3. Ne pas couper le cordon d'alimentation avec le commutateur. Ceci entraînerait l'annulation de la garantie.

4. Certifications

POWER SUPPLY



Parts recognized by the UL laboratories.



Certification of the Underwriters Laboratories in relation to the product's safety.



Warning

1. Always connect LED load before connecting power source!
2. Please follow all regulation and do not install without conform protection at less than 3 inches of all insulation.
3. Do not cut the power cord and the connexion pod. This will void the warranty.